

外觀尺寸 / DIMENSIONAL DRAWING

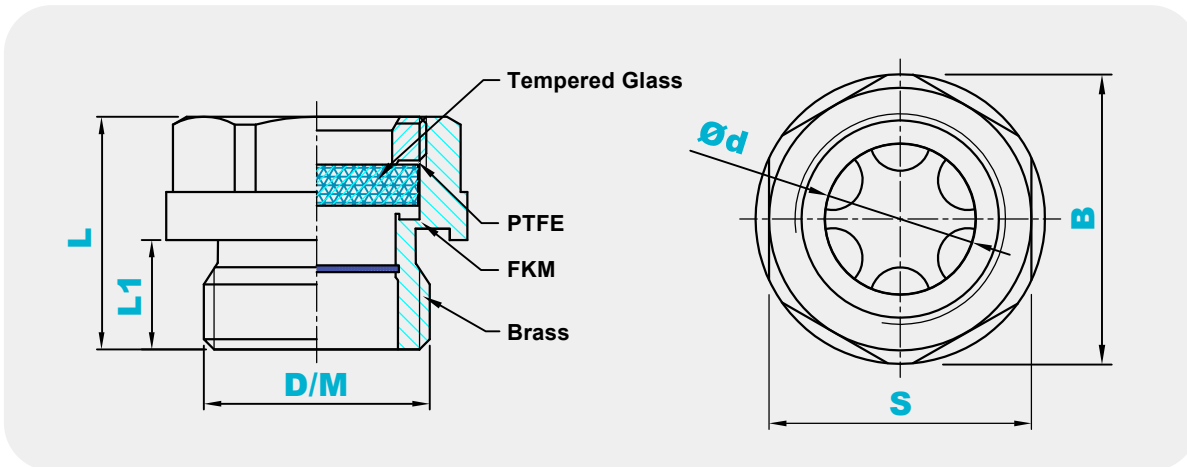

技術要求 / NOTE

- 鍛件表面不得有裂紋、缺口、塌陷、冷隔等缺陷
Creak, notch sink, cold shut and other defetives are not allowed
- 未注倒角去尖倒稜
Unless otherwise specified, chamfer sharp edge
- 未注形位公差等級按(GB1184-80) 取C級
Unless otherwise specified, use grade C for geometric tolerance
- 未注尺寸公差應符合公司規定M級的要求
Unless otherwise specified, use grade M for dimensional tol
- 表面本色 Surface : Raw

性能要求 / TECHNICAL STANDARD

- 100% 螺紋規檢驗
100% thread gauge inspection
- 溫度範圍在-30°至150°
The applicable temperature is -22°F to 302°F
- 常溫下(40°C) , 壓力範圍在0.8Mpa內
The applicable pressure at normal temperature (104°F) is within 120 PSI

技術參數 / TECHNICA PARAMETERS

型號 TYPE	D	M	B	S	L	L1	Ød
OM-02 GW	G 1/4	M14*1.5	19	16	18	8	8.5
OM-03 GW	G 3/8	M16*1.5	22	19	19	9	10
OM-04 GW	G 1/2	M20 / 22*1.5	25/26/27	22/23/24	20	10	13.75/16
OM-06 GW	G 3/4	M26 / 27*1.5 / 2.0	32	29	20	10	19/20
OM-08 GW	G 1	M33*1.5 / 2.0	38	35	22	11	25
OM-10 GW	G 1-1/4	M42*1.5 / 2.0	49	45	23	11	33
OM-12 GW	G 1-1/2	M48*1.5 / 2.0	55	50	23	11	38
OM-16 GW	G 2	M60*2.0	68	62	24	12	48

未注公差		
線性公差	垂直度	同軸度
≤ 20mm	± 0.10	0.10 mm
≤ 20mm-60mm	± 0.20	
≥ 60mm	± 0.30	

比例	1 : 1
名稱	黃銅銑六角油鏡
規格	BSP (G) / Metric
型號	OM-GW

