

外觀尺寸

DIMENSIONAL DRAWING

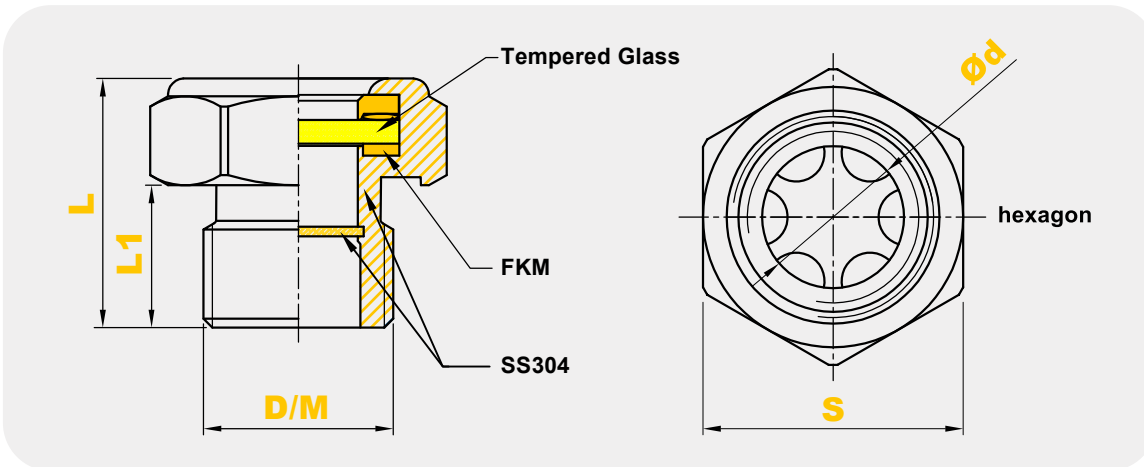

技術要求

NOTE

- 鍛件表面不得有裂紋、缺口、塌陷、冷隔等缺陷
Creak, notch sink, cold shut and other defetives are not allowed
- 未注倒角去尖倒稜
Unless otherwise specified, chamfer sharp edge
- 未注形位公差等級按(GB1184-80) 取C級
Unless otherwise specified, use grade C for geometric tolerance
- 未注尺寸公差應符合公司規定M級的要求
Unless otherwise specified, use grade M for dimensional tol
- 表面本色 Surface : Raw

性能要求

TECHNICAL STANDARD

- 100% 螺紋規檢驗
100% thread gauge inspection
- 溫度範圍在-30°至150°
The applicable temperature is -22°F to 302°F
- 常溫下(40°C) , 壓力範圍在1.6Mpa內
The applicable pressure at normal temperature (104°F) is within 230 PSI

技術參數

TECHNICA PARAMETERS

型號 TYPE	D	M	S	L	L1	Ød
OMA-02 GS	G 1/4	M14*1.5	19	17.8	8	8.5
OMA-03 GS	G 3/8	M16*1.5	22	18.8	9	10
OMA-04 GS	G 1/2	M20 / 22*1.5	27	20	10	13.75/16
OMA-06 GS	G 3/4	M26 / 27*1.5 / 2.0	32	20.5	10.5	19/20
OMA-08 GS	G 1	M33*1.5 / 2.0	40	23.8	12	25
OMA-10 GS	G 1-1/4	M36*1.5	46	25	13	28
OMA-12 GS	G 1-1/2	M42*1.5 / 2.0	50	27	14	33
OMA-16 GS	G 2	M48*1.5 / 2.0	55	27	14	38

未注公差			
線性公差		垂直度	同軸度
≤ 20mm	± 0.10	0.10 mm	Ø0.15 mm
≤ 20mm-60mm	± 0.20		
≥ 60mm	± 0.30		

比例	1 : 1
名稱	不鏽鋼六角油鏡
規格	BSP (G) / Metric
型號	OMA-GS

